



# GAZETTE

Vol. 15, No. 2

Pemigewasset Valley Fish and Game Club

June 2009

## inside

- 2 Director's Corner
- 3 2009 Event Calendar
- 4 President's Firing Point
- 5 Archery, IDPA
- 6 Club Clean-up Day
- 7 Women on Target
- 8 Biathlon  
High Power Rifle
- 9 State M1 Garand Cham-  
pionship  
Adopt-a-Highway
- 10 Silhouette
- 11 Win Staples Special  
Recognition
- 12 Officers and Directors  
Contributors



## The Patron Program at Work

(see page 11)





## Fish New Hampshire and Relax

By Glenn Normandeau, Executive Director,  
N.H. Fish and Game Department

Spring is here, and there's no better time to enjoy fine fishing in New Hampshire. Fish and Game helps keep things exciting by stocking over a million rainbow, brook and brown trout every year for your fishing pleasure (visit [www.fishnh.com](http://www.fishnh.com) for recent stocking locations). Saturday, June 6, is free fishing day in New Hampshire, so get out and give it a try. We think you'll be hooked in no time.

Inland, New Hampshire has tremendous salmon fishing; fisheries biologists tell us Lake Winnepesaukee will continue to produce landlocked salmon in the 17-21 inch range this year. You can tramp up to a mountain stream or remote pond for colorful brookies. Over at the coast, it won't be long before the mackerel and stripers are in.

Broodstock salmon are back this year, too. May into early June is prime time for New England's only managed broodstock Atlantic salmon fishery. We're stocking hundreds of 3- and 4-year-old salmon averaging more than 8 pounds each into the Merrimack and Pemigewasset rivers. Catching these big beauties is quite a thrill.

Trout get a lot of the limelight, but New Hampshire's strong warmwater fisheries offer action-packed fishing, too, from bass, pike and pickerel to perch and pumpkinseeds. This issue of the *Journal* suggests ways to diversify your fishing experience by fly-fishing for these challenging warmwater species.

Whatever type of fishing you do, remember to pick up after yourself when you go out to enjoy the outdoors. Don't leave your worm containers, cans and wrappers around to muck up the landscape. Don't clean your fish in and around waterbodies. If we want to maintain the fishing tradition, we need to be mindful that a great deal of our access is a privilege we have because of the generosity of private landowners.

On another note, we're in the midst of our annual appeal to raise matching funds for the Nongame and Endangered Wildlife Program. The campaign wraps up June 30. Before then, we have to raise private donations to qualify for a \$50,000 matching grant from the state. These private donations and the state money also help toward a match for federal State Wildlife Grant funds. This money benefits all wildlife in the state, because habitat issues relating to nongame wildlife are just as important for game species.

So get out and enjoy the season. Take a kid along if you're going fishing (kids under 16 fish free). It's a great way to get them outside and into the natural world. Licenses and moose lottery applications are available online 24/7 at [www.fishnh.com](http://www.fishnh.com). Thanks for your support.

Excerpted with permission from *N.H. Wildlife Journal*, January/February 2009.

### SKIP'S GUN & SPORT SHOP

Store Hours  
Tues.-Sat.  
10 A.M.-6 P.M.

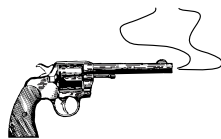

Gunsmithing  
Service  
by Appointment

Harold T. "SKIP" Reilly, Sr.

Authorized Remington Warranty Station

837 LAKE STREET • BRISTOL, NH 03222

(603) 744-3100 • fax (603) 744-3111

[www.nhskip.com](http://www.nhskip.com)

### PEMI FIREARMS

85 Blair Road • Campton, NH 03223

*Good Guns for Good People*

New • Used • Accessories • Ammo

Hours: Th-F 5-8 pm ~ Sat. 9am-5pm ~ Sun. by appt.

**530-2353**

[pemifirearms@roadrunner.com](mailto:pemifirearms@roadrunner.com)

## 2009 Schedule of Events

NOTE: See Gazette articles or the club website, [www.pemi.org](http://www.pemi.org), click on Event Schedule for more details of these listed events.

Wed., June 3 Board of Directors monthly meeting. 7pm  
Sat., June 6 Summer biathlon # 1 (200-yard range)  
Sun., June 7 Silhouette: cowboy lever action (200-yard range)  
Sat., June 13 NHHPR L # 2, then slow prone (200-yard range)  
Sat., June 20 NH State M1 Garand Championship (200-yard range). See page 9.  
**► Thur., June 25 Monthly club meeting. 7pm at the clubhouse.**  
Sat., June 27 Highway clean-up, 2 of 4. See page 9.  
Sat., Sun., June 27, 28 3-D archery: IBO State Championship (all ranges). See page 5.  
Wed., July 1 Board of Directors monthly meeting.  
Fri., Sat., Sun., July 10-12 Cowboy Action Shooting: the Fracas (200-yard range)  
Sat., July 18 Summer biathlon # 2 (200-yard range)  
Sat., July 18 Women on Target (clubhouse, covered firing ranges). See page 7.  
Sun., July 19 NHHPR L # 3, then slow prone (200-yard range)  
Sun., July 19 Card shoot, fund-raiser (50-yard range, 1pm-sunset)  
Sat., July 25 IDPA  
Sun., July 26 Silhouette (covered ranges)  
**► Thur., July 30 Monthly club meeting. 7pm at the clubhouse.**  
Sun., August 2 3-D archery shoot # 2 (all ranges). See page 11.  
Wed., August 5 Board of Directors monthly meeting. 7pm  
Thurs, Fri. August 6,7 Bowhunter education (clubhouse, 6-9pm). See page 8.  
Sat., August 8 Bowhunter education (clubhouse, 8am-5pm)  
Sat., Sun., August 8, 9 Machine gun shoot (200-yard and covered ranges)  
Sat., August 15 Summer biathlon # 3 (200-yard range)  
Sun., August 16 NHHPR L # 4, then slow prone (200-yard range)  
Sat., August 22 Highway clean-up, 3 of 4. See page 9.  
Sat., August 22 Silhouette: cowboy lever action (200-yard range)  
Sun., August 23 Cowboy Action Shooting (200-yard range).  
Sun., August 23 Silhouette (covered ranges)  
**► Thur., August 27 Monthly club meeting. 7pm at the clubhouse.**  
Sat., August 29 IDPA  
Sun., August 30 3-D archery shoot # 3 (all ranges). See page 5.  
Wed., September 2 Board of Directors monthly meeting. 7pm  
Sat., September 12 50-meter small-bore rifle match (covered range)  
Sat., September 19 Summer biathlon orientation match / fun shoot. See page 8.  
Sun., September 20 NHHPR L # 5 (200-yard range) then 50m small-bore match (covered range)  
**► Thur., September 24 Monthly club meeting. 7pm at the clubhouse.**  
Sat., September 26 Silhouette: cowboy lever action (200-yard range)  
Sun., September 27 Silhouette (covered ranges)  
Sat., October 3 IDPA  
Sun., October 4 Mountain bike biathlon

Wed., October 7 Board of Directors monthly meeting.  
Sat., October 10 NHHPR L # 6 (200-yard range) then 50m small-bore match (covered range)  
Sun., October 11 International Plymouth small-bore rifle (50-yard covered range)  
Sat., October 17 Highway clean-up, 4 of 4. See page 9.  
**► FRIDAY, October 30 Monthly club meeting. 7pm at the clubhouse.**  
Sat., October 31 IDPA  
Wed., November 4 Board of Directors monthly meeting. 7pm  
Wed., December 2 Board of Directors monthly meeting. 7pm  
**► FRIDAY, December 4 Combined Nov+Dec Monthly club meeting "Christmas Social" 7pm at the clubhouse.**

NOTE: See Club Website, [www.pemi.org](http://www.pemi.org) and click on event schedule for more details.

**INDOOR RANGE:** 8 a.m. to 9 p.m. with key. Call Phil Haskell, 536-3105, or John Bartlett, 786-9720, to obtain a key. Team and open shooting from 6 p.m. Monday and Thursday evenings. Members only—log in and out with current membership number at range; \$5 per day. Memberships available at range.

**OUTDOOR RANGES:** 8 a.m. to dusk, 7 days a week, closed during archery shoots (see schedule of events) until about 4:30, and at other announced times for scouting events, etc. Members only—log in and out with current membership number; \$5 per day range fee. May sign up for membership at range. Info: Fred Allen 968-9944 or [mail@pemi.org](mailto:mail@pemi.org).

**TRAP RANGE:** Open shooting (launch your own birds) 8 a.m. to dusk, 7 days a week. 12 gauge and smaller, #7½ and #8 shot only. **No other firearms on trap range!** Club trap, open to all members and membership available on site, Thursday evening 5 p.m. to closing under lights. Call Randy Montague at Yeaton Agway, (603) 536-4554 for info. **Five-stand fun Sunday mornings from 8 a.m. Call Denny Sutcliffe at 536-4435.**

**OUTDOOR ARCHERY:** Practice range and 15-station course open all times except during certain announced events. \$5 per session. Info: Fred Allen at 968-9944.

See Pemi website at [www.pemi.org](http://www.pemi.org) or e-mail [mail@pemi.org](mailto:mail@pemi.org) for further details and schedules.

### YEATON AGWAY SERVICES

Open 8–5 Every Day 4-U

Highland Street, Plymouth, NH 03264  
Telephone (603) 536-4554



7 Town West Rd., Tenney Mtn. Hwy., Plymouth · 536-4908  
[www.thegarantybank.com](http://www.thegarantybank.com) Member FDIC

## The President's Firing Point

The elections in March produced a number of changes, including a new president for the first time in 15 or 16 years. For better or worse, I'm your new president, and I thought it would be a good idea to introduce myself. First, though, I want to recognize Fred Allen's long service to the Club and his tremendous devotion to its success. Fred says that although he's stepping down from the president role, his love of the Pemi hasn't diminished, and he'll continue to be active in the Club. And indeed, he's still serving the Club as a member of the Board.

I couldn't begin to devote the hours to the Club that Fred has over the many years — I'm not sure we'll ever see that again — and that's not my goal. My goal, instead, is to try to harness the skills and energy of you, the Club members. One of the first things to that end that I'll do is to try to make more of the Board's functioning visible to the rest of the Club, so that you know more about what's going on and so you'll know how to pitch in.

I've been a member of the Pemi since 1989 (having gotten my start via the Club's CMP efforts — back then it was called the "DCM"), but it's only when I retired from the software biz in 2004 that I was able to join the Board of Directors and spend more time at the Club. One of the things that struck me was how many things are going on at the Club, not only all the shooting activities, but also the projects to improve the Club and the community outreach. I certainly hope to continue to encourage all that, but I also hope to do more to let all the members know what's going on, and with that, draw in every member. So talk to me, talk to the other members on the Board, and tell us what goals you would like to see the Club pursue, and what you can do to help us achieve those goals. Remember, it's your club.

### Election Results

In addition to a new president, we have a new secretary, Brian Pelchat, who replaces Jeff Lindblom (who moved to Missouri for a new job), a new treasurer, Stuart Pitts, who replaces Paul Rheinhardt, and four new directors: Tim Korade (who is rejoining the Board after a several year hiatus), Bob Klimm, Tom Grabiek, and Jerry Thibodeau. Fred Allen remains on the Board, as a director. The rest of the Board remains unchanged.

### Clean-up Day

We had a great turn-out on April 25th for our annual clean-up day. Mother Nature greeted us with great weather, too, as you can see from the pictures on page 6. About two dozen folks pitched in to clean up the ranges, clean out and re-organize the shed at the covered firing ranges, fill up the water barrels, trim brush from the side berms at the 50- and 100-yard ranges, clean out the indoor range, spread some top soil, re-build part of the pit wall on the 200-yard range, trim brush along the power lines, spruce up the gardens, push back some of the dirt pile on the driveway at the street, sweep the sand off the driveway, polyurethane the new pine paneling for the upstairs of the clubhouse, and more. Thanks to everyone. Lunch was served, cooked by Arthur Alfors. I'm embarrassed that we missed one helper dur-

ing the call to lunch, so, Leo, sorry, and I owe you a lunch sometime.

Special thanks first to Paul Rheinhardt, who brought his excavator and made it possible to repair the worst part of the pit wall damage. Then also to Brendan Beckley, whose tractor got put to good use on the ranges and by the driveway. And to Brian Klimm for using that neat power broom to clear the winter sand off the driveway; it was faster than about 10 people with push brooms. And to Tim Korade, whose power sprayer made polyurethaning the pine boards go much, much faster.

### Mowing

One job that goes a long way towards keeping the Club looking nice is mowing the lawn. Fred's been doing the mowing himself for many years now, and it's time to share the load. To that end, Don Marsh has started a calendar for lawn mowing, where people can sign up for a turn at mowing. So give Donny a call at 968-7039 and volunteer to ride the mower over the club's lawns once or twice this summer. Don will meet you there, if you wish, to show you how the mower works.

### Membership Renewals

The new membership year started April 1st, and Phil Haskell, our database manager, reports that only about half of our members have renewed as we go to press. If you haven't gotten around to it, please take this opportunity to send in the blue membership card that came in the March Gazette. Or, pick one up at the club next time you're here. Or, see the on-line form at [www.pemi.org](http://www.pemi.org).

### The Paneling Project

On Saturday, May 16th, the paneling of the upstairs of the clubhouse got under way. (The pine was polyurethaned on clean up day, as noted above.) A half dozen or so folks, let by Jerry and Nick, managed to get about a quarter of the upstairs done. This project is being funded by donors to the 2008 Patron Program. To you folks, thanks! The paneling, along with the insulation, the new windows, and the ceiling, will make a radical improvement in the usefulness of the upstairs. See the pictures on page 1.

### What Else?

Lots of other projects are going on, too many for a complete list here (and I've rambled on already too long). But some of the key ones include finishing the picnic pavilion (to be done as part of an Eagle Scout project), expanding and possibly relocating the high power range, improving the indoor range air-handling system, and instituting a more formal budget process. Members are welcome to attend Board meetings, and that's a good time to hear about the many activities going on at the Club.

Be safe.

-Randy

# SAFETY FIRST

## Archery Notes

The Pemi club will host three 3-D archery shoots this summer. Read on and plan to take part!

The first will be held on Saturday and Sunday, June 27 and 28. This is the IBO (International Bowhunter's Organization) sanctioned NH State 3-D Championship. There are over 30 classes recognized and all IBO rules apply. (See them on the IBO website, [www.ibo.net](http://www.ibo.net).) The entry fee is \$25 adults, youth \$15, cubs \$10 and future bowhunters free. The shoot will have two separate 15-target rounds, all at 3-D targets, mostly Mckenzie targets. You may split the event into 15 targets each day or do it all in one day; it takes around four to five hours to do the entire shoot. Registration begins at 7:30 each day and the scoreboard closes at 5:00 Saturday and 3:00 sharp on Sunday. Burgers, dogs, drink and goodies available both days!

Then on Sundays, August 2 and 30, we will host family-friendly, hunting-oriented 3-D shoots. There will be 17 or 18 targets on each of two rounds and you only turn in 15 scores each round ..... the decision to skip a target is final, just as in hunting! Most targets will present some sort of a hunting situation to make it interesting. The divisions are adult male, adult female, youth age 10-15, and FBH age 9 and under. The classes are compound and traditional. There will be interesting side shoots and the usual grub will be available. Great shoots for someone getting started in 3-D archery! The fee is only \$10 adults, youth \$5, FBH free with a family maximum of \$25.

The practice target butts on the lawn and the 15 target practice course are available 24/7. You must be a member to use these other than in an event and the range fee is \$5. The range fee entitles one to access to all the club ranges that are not in use for an event.

For information call archery chairman Fred Allen at 603-968-9944, email to [mail@pemi.org](mailto:mail@pemi.org) or consult the club web site, [www.pemi.org](http://www.pemi.org), click on Archery.

### June 27, 28: The NH State Archery Championship

<http://pemi.org/calendar/wc20090628.html>  
Fred Allen, [mail@pemi.org](mailto:mail@pemi.org)

### July 10-12: The Fracas at Pemi Gulch

<http://pemi.org/calendar/wc20090711.html>  
Skip Maloney, [mlnygry@aol.com](mailto:mlnygry@aol.com)

### August 8, 9: The Machine Gun Shoot

<http://pemi.org/calendar/wc20090808.html>  
Jerry Thibodeau, [jerry@thibco.com](mailto:jerry@thibco.com)

## What is "IDPA"?

The sharp-eyed among you might have noticed that there are several dates on the calendar now for something called "IDPA". IDPA is the International Defensive Pistol Association, the governing body of a shooting sport that simulates self-defense scenarios and real life encounters.

This is from their website at [www.IDPA.com](http://www.IDPA.com):

[IDPA] was founded in 1996 as a response to the desires of shooters worldwide. The organization now boasts membership of more than 13,500, including members in 36 foreign countries. One of the unique facets of this sport is that it is geared toward the new or average shooter, yet is fun, challenging and rewarding for the experienced shooter. The founders developed the sport so that practical gear and practical guns may be used competitively. An interested person can spend a minimal amount on equipment and still be competitive. The main goal is to test the skill and ability of the individual, not equipment or gamesmanship. "Competition only" equipment is not permitted in this sport.

We've started an IDPA program at the Pemi this year, headed up by Bob Klimm. Contact him at [rklimm@strat-edg.com](mailto:rklimm@strat-edg.com) or 603-630-9408 for more information.

The first IDPA match at the Pemi was to happen just after we went to press. Dates for the balance of this season are:

July 25<sup>th</sup> Aug 29<sup>th</sup> Oct 3<sup>rd</sup> Oct 31<sup>st</sup>

## SAMYN • D'ELIA ARCHITECTS, P.A.

Tom Samyn, AIA  
Ward D'Elia, AIA

*Serving New Hampshire for over 20 years.*

P.O. Box 1259, Ashland, NH 03217 • (603) 968-7133  
e-mail: [sdarch@cyberportal.net](mailto:sdarch@cyberportal.net)



Community Guaranty Savings Bank

*People who know you.*

*People you know.*

P.O. Box 996, 28 South Main Street  
Plymouth, New Hampshire 03264

Tel. (603) 536-0001 Fax (603) 536-2222

Campton office: 21 Tower Rd., Campton, NH 03223

Member  
FDIC



## CLEAN-UP DAY

I forgot to get the camera out until the very end of the day, so here's just a small sample of what we did on clean-up day. You can tell from the t-shirts and the shadows that it was a beautiful day.

Thanks to all two dozen people who came out to help!



## The Pemi Gazette Available by E-mail

We'd like to remind everybody that the Pemi Gazette is available on-line, and you can choose to get an e-mail alert as it becomes available. If you choose this, you will get it sooner, and save the Club the printing and postage costs.

The e-mail alert will be a small text file that has a link to the latest Gazette. Click on the link to read the Gazette, save it on your own computer, or print it out at home. The e-mail message will be tiny and will not significantly impact your e-mail service or your storage quota, and it will include any breaking news about events or schedule changes that happen after the paper Gazette goes to press.

To choose this option, just send e-mail to Phil Haskell at [three\\_birches@yahoo.com](mailto:three_birches@yahoo.com).

E-mailing the Gazette could save a lot of money on printing and postage for the Club. We have e-mail addresses for 62% of the 2008 membership, but so far only a tiny percentage of those have opted for the e-mail version.

Your Board of Directors is looking for ways to save money and keep our membership fees as low as possible. Eventually we would like to switch over to as many of the e-mail Gazettes as possible. For the foreseeable future, you will always have an option to choose which version you want - printed or e-mail.

## Target Frames for the 50– and 100-yard ranges

A good project for all shooters: help keep frames stocked on the sport ranges

Cut each of two 12' pieces of strapping — the Club has a supply at the BBQ pit (between the clubhouse and the garage) — into three pieces

1. an 8'6" piece (the upright)
2. a 3' piece (a crosspiece)
3. and a 6" piece (a support piece)

Notch one end of each 8'6" piece and saw a 12"-long slot that will accept the wire on the range. This will be the top of the upright. See figure 1.

Nail or screw the two 3' crosspieces 20" apart (inside measurement), with the upper crosspiece 25" from the top of the uprights. Allow the crosspieces to extend 1" - 1 1/2" beyond the uprights to help prevent splitting. See figure 2.

The 6" pieces can be added on the inside of the uprights under a crosspiece to stiffen the whole frame.

That's it!

Making frame "kits" and leaving them at the ranges is good, too. It's trivial to assemble a frame from the parts. If you make frames at home, transporting just the kits is a lot easier.

Thanks!

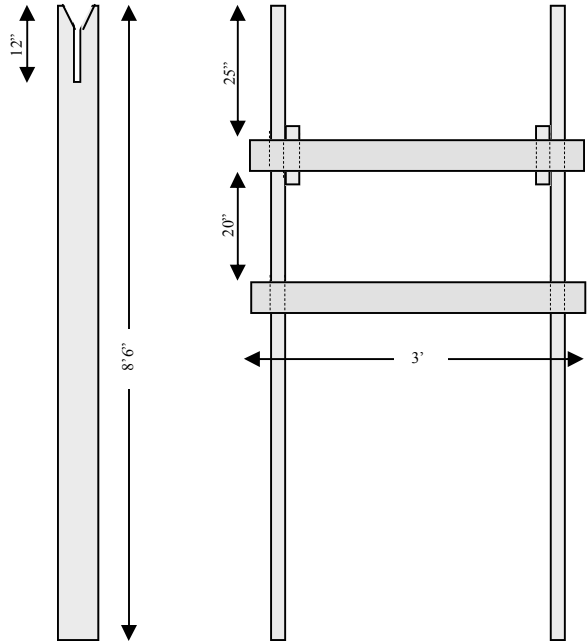

Figure 1

Figure 2

## Women on Target July 18, 2009

Our annual Women on Target event will be on Saturday, July 18, 2009, from 10 am to about 1 pm. This is an informal introduction to pistol and rifle sport shooting for women who may have little or no shooting experience. It's open to all women and girls — age 16 and up, maybe a little younger if Mom comes along. We'll do some classroom instruction at the clubhouse, followed by hands-on practice at the 50 yard covered range, with both .22 pistol and .22 rifle. The cost is only \$10; and we'll provide everything you need. Pre-registration is required; contact Ev Tate to sign up.

This'll be the sixth year that we've done this program; everybody has a great time, both guests and coaches. So please pass the word along to your friends, relatives, colleagues, neighbors. And if you'd like to help out as a coach, please contact Ev; the more volunteers, the better.

Ev Tate  
phone 978-443-5429  
email [evtate@verizon.net](mailto:evtate@verizon.net)

(603) 968-3311

**ASH**  
*True Value*<sup>®</sup>  
**HARDWARE**

DICK ASH  
RICK ASH

20 MAIN STREET  
ASHLAND, NH 03217

For All Your Building Material Needs  
**Ashland Lumber Company, Inc.**  
Ashland, NH 03217 Exit 24 off I-93

(603) 968-7626

You Deserve The Best

Toll Free 1-800-649-2076 • Fax (603) 968-3665

## SUMMER BIATHLON – A SPORT FOR EVERYONE!

The club will host five summer biathlon events in '09! With walk classes as well as several running classes everyone is urged to take part! Plus, this year there will be a wheelchair class added in cooperation with New England Disabled Sports, allied with Disabled Sports, USA. We have loaner rifles and coaching is available. All events are family oriented and the whole family is invited to participate.

The first three, on Saturdays June 6, July 18, August 15 pit our biathletes against the team from Harvard Sportsmen's Club in Harvard, MA. This is our third year of biathlon and of competition with Harvard and we squeaked out wins both of the previous years. The top four scores count for the competitions so come and help us take the trophy another year!

The fourth session, on September 19, will be a fun shoot with an orientation clinic and you can just shoot, or run and walk, listen, watch and socialize. The usual burgers, dogs, drink and goodies will be available for a modest fee.

And on October 4 there will be a mountain bike biathlon where the running and walking is replaced by a mountain bike course!

The registration fee is only \$10 for each event except it will be \$15 for the August 15 date which is the Championship Shoot in our competition with Harvard. Or, a one-time non-refundable fee of \$35 for the first four events or \$45 for all five.

For further information, call Fred Allen, biathlon chair, at 603-968-9944 or email to [mail@pemi.org](mailto:mail@pemi.org). The club web site is [www.pemi.org](http://www.pemi.org) ..... click on Biathlon in the menu on the home page.

## Attention Indoor Range Shooters

For access to the Indoor Range, shooters need the key they received when they qualified, *and* the combination for the entryway door. The combination was changed just after March 31, 2009.

Indoor Range shooters should keep the key they were issued when they qualified, and use that key and the new combination to get into the range. Shortly after you pay the \$10 indoor range key on this year's BLUE application card, we will email you the new lock combination and instructions on how to get in. Be sure to include your email address and/or phone number on the card. Email is the preferred way for us to stay in touch.

If you have any questions about the Indoor Range, please contact Phil Haskell at [three\\_birches@yahoo.com](mailto:three_birches@yahoo.com) or John Bartlett at [bartlett357@roadrunner.com](mailto:bartlett357@roadrunner.com).

## High Power Rifle

The high power rifle season is under way. As we go to press, we've already had our CMP clinic, a long-range match, and one League match.

"League match": A lot of our high power competition every year is done in matches associated with the New Hampshire High Power Rifle League. This is a collection of four clubs in the state. Each of the four clubs in the League runs 5 or 6 matches a year. Shooters from all the clubs can shoot at any or all of these matches, and it's a great way to meet shooters from other parts of the state. The matches themselves are relatively quick: 50-shots, mostly rapid fire, with plenty of sighters.

Registration starts at 7:00am for each match, with the goal of getting the first shot off at 8:00am. The cost for adults is \$12.00 per match plus a \$5.00 registration fee once per season, but juniors shoot **free** ... and the League **supplies ammo** (.223 or .308) for juniors shooting the match.

The Pemi's next NHPRL match of 2009 is Saturday, June 13<sup>th</sup>. See the schedule on page 3 for the dates of all the matches, or contact Randy Enger for more details: 978-443-5429 or [randyenger@verizon.net](mailto:randyenger@verizon.net).

A twist that we add at the Pemi is that each League match is followed by a separate 20-shot prone match. We'll typically shoot on the 200-yard line, using the MR-52, but towards the end of the season, we might switch over to small-bore, to practice for the International Plymouth match in October. Or maybe we'll do both!

**ISLAND FISHING CHARTERS**  
Trolling for salmon, lake and rainbow trout on  
Lake Winnepesaukee

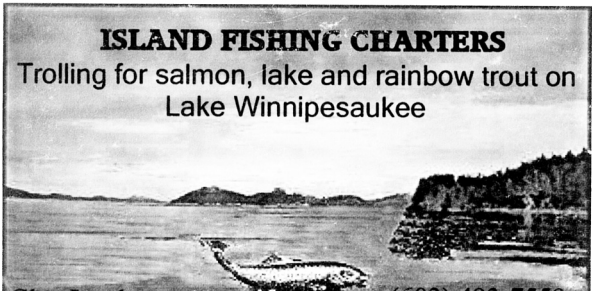

Glen Leathers (603) 493-7559  
[GLEATHERS@comcast.net](mailto:GLEATHERS@comcast.net) [www.islandfishingcharters.com](http://www.islandfishingcharters.com)

# GO-NH SSP NH STATE JOHN C. GARAND CHAMPIONSHIP

## June 20, 2009

**Rules:** 2009 CMP and NRA rule books in full force and effect as applied.

**Eligibility:** Open to any US citizen, 16 years of age or older. All participants must have a notarized CMP Eligibility Affidavit on file with the CMP.

**Entry Fees:** \$30.00 includes required ammunition and awards. Make checks payable to SSPC.

**Entries:** Open at 0730 on range and close promptly at 0830. Personnel arriving after 0830 WILL NOT fire.

**Squadding:** Will commence at close of entry table.

**Mandatory Safety Briefing/Orientation:** Will commence at close of Squadding. Competitors must have prior rifle tournament experience or have attended a Service Rifle Clinic.

Firing will commence at 0900.

**Rifles Allowed:** ONLY US Rifle, cal. .30 M1(Garand). Competitor rifles must conform to the 2009 CMP Rule Book. Rifles chambered for 7.62mm NATO (.308 Winchester) prohibited.

**Ammunition:** Competitors will be issued 60 rounds of ammunition for sighting shots and record firing. Competitors must provide their own clips.

**Course of Fire:** CMP Rifle Course "B". Five sighting shots and 50 rounds for record, fired at 200 yards on the SR target.

Stage 1, five sighting shots and 20 rounds for record prone slow in 25 minutes.

Stage 2, 10 shots for record, standing to prone, rapid fire, 70 seconds.

Stage 3, 10 shots for record, standing to sitting or kneeling, rapid fire, 60 seconds.

Stage 4, 10 rounds for record, off hand, standing, slow fire, 10 minutes.

Remaining in position for rapid fire strings may apply for 2009.

**Alibis:** No alibis or re-fires allowed due to rifle or ammunition malfunctions.

All Competitors are required to score and pull targets. Bring your own lunch, drinks, and rain gear. Special medals will be given for placement in the tournament based on the 2009 medal guidelines. Competitor rifles and equipment are subject to inspection by the tournament director, or his designee, for rule compliance. Map to range can be found at [www.pemi.org](http://www.pemi.org).

**Tournament Director:** George R. Gurick, Jr., [pemihpc@hotmail.com](mailto:pemihpc@hotmail.com), 603-859-1949 after 1800.

**Proceeds:** All proceeds fund Junior and Senior Rifle and Pistol Teams for the 2009 National Matches.

## Adopt-a-Highway

We perform a civic duty in doing highway cleanup in the state-wide Adopt-a-Highway program. We will continue this effort in 2009, and your assistance is needed and will be appreciated. We used to do a section of Tenney Mountain Highway in Plymouth, and the steep banks on much of our section made it a pretty strenuous job. But we now have a very flat stretch of Route 175 from the Holderness School to 7 Pines Road.

At the April 18th clean-up, about 10 people showed up, and it took only about an hour or so to finish "our" stretch.

Please mark your calendar for the remaining three highway cleanup days in 2009:

- June 27th
- August 22nd
- October 17th

(All are Saturdays.)

Call Winnie Oustecky at 536-4129 for more information.



P.O. BOX 420 • 63 MAIN STREET  
PLYMOUTH, NEW HAMPSHIRE 03264-0420

255 DANIEL WEBSTER HIGHWAY  
MEREDITH, NEW HAMPSHIRE 03253

PHONE (603) 536-1735 • FAX (603) 536-4298  
(603) 279-3232



### PLYMOUTH ANIMAL HOSPITAL

Quality Health Care for Large and Small Animals  
24-hour Emergency Service

David W. Cote DVM  
Ellyn K. Tighe DVM  
Miles Moritz DVM  
Fred R. Allen DVM, retired

Tenney Mountain Highway  
Plymouth, NH 03264  
Hours by Appointment  
(603) 536-1213

# Cowboy Lever Action Match Results

April 26, 2009

We went from a threat of incredibly hot muggy weather to a short period that threatened rain, however neither happened, and we shot under excellent conditions, with high clouds, good visibility, and even lighting. Dick Bishop of Nashua topped the field with his AAA class score of 32, followed by two new shooters to this sport, Bob Thurston of Moultonborough with a 29, and Joel Fisher of Gilford posting a 28. Of note was John Livingston's ten in a row pig count, his first step toward that elusive grand slam when the shooter collects ten in a row of all four animals (not necessarily in the same match). Remember that some of the guns being shot are over 100yrs old.

In the open match, where we allow guns other than lever actions and accommodate special cases, we had two impressive entries. Tom Corvalha, who drove 3 hours from southern Mass., shot his Rem XP100 pistols from the Creedmore position (laying on the ground, shooting over a bent leg), and not coming far from that perfect 40 score. Brian Giblin of Salisbury, Ma., came to the match with his grandfather Paul Kendall of Alexandria. Brian shot a 30-30 lever gun, but only had enough ammo to shoot a bank of 5 on each animal. This young man showed real potential as shown by his scores like three out of five rams knocked down at 200yds, shooting offhand.

Congratulations to all.

Don't forget to mark your calendar for our next 200-yard Cowboy Lever Action silhouette match on June 7 and the regular 100-meter match on July 26. Then in August we are holding a two-day, two-event weekend on Saturday and Sunday the 22nd and 23rd, giving all who care to an opportunity to camp over and share a campfire.

There is much more information on our website, [www.pemi.org](http://www.pemi.org). Or, contact John Bartlett by phone at 603-786-9720 or by email at [Bartlett357@roadrunner.com](mailto:Bartlett357@roadrunner.com) if you have any questions.

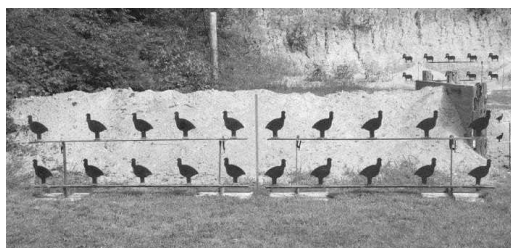

## Match No. 1

Competitor	Class	Chickens	Pigs	Turkeys	Rams	Total	Place
Bob Thurston	U	9	9	6	5	29	second
Bob Santoro	AA	8	9	6	3	26	
Bruce Jorgenson	U	7	9	4	2	22	
Bill Ross	AA	7	7	4	6	24	
Dick Bishop	A	9	5	4	5	23	
John Livingston	AA	7	7	4	6	24	
Skip Holmes	A	9	8	5	4	26	
Bob Poole	AA	9	7	4	2	22	
Chuck Theriault	A	9	6	4	3	22	
Joel Fisher	U	9	9	6	4	28	third

## Match No. 2 (re-entries)

		Chickens	Pigs	Turkeys	Rams	Total	
Bill Ross	AA	7	7	4	3	21	
Dick Bishop	A	9	9	8	6	32	first
John Livingston	AA	7	10	4	7	28	
Skip Holmes	A	9	8	3	7	27	
Chuck Theriault	A	7	7	5	4	23	

## Pemi Open Match

	Chickens	Pigs	Turkeys	Rams	Total	
Thomas Corvalha	9	10	10	9	38	(match 1)
Thomas Corvalha	8	10	9	8	35	(match 2)
Brian Giblin	1/5	4/5	2/5	3/5	10/20	

## A Special Recognition for Win Staples



Win and Shirley Staples

Win holds a plaque presented to him for his long-time dedication to the club and its goals. Win was president of the Pemi in 1952 and guided the building of the clubhouse.

## Club Goals

- Conservation of habitat, fish, and wildlife
- Good sportsmanship, safety, and outdoor ethics
- Proper management of fish and wildlife resources
- Promotion and preservation of the shooting sports

## The Patron Program

Please consider becoming a Patron Member when you renew your membership. Sign up on the 2009-2010 membership application card.

The three patron membership categories are Club Guardian at \$100 per year, Sentry at \$75 and Lookout at \$50. Each year the Patron donations will be applied to a special project with long-term benefit to the club and a plaque or other tribute will be displayed at the clubhouse honoring those donors. The 2008 donations are being used to put up knotty pine boards to cover the newly-insulated walls on the upper floor of the clubhouse. (See some pictures of the work on page 1.)

## Bowhunter Education Course

The Club's Bowhunter Education team announces that this year's course will be held at the clubhouse Thursday and Friday, August 6th and 7th, from 6 to 9pm, and Saturday, August 8th, from 8am to 5pm. Attendance at all three sessions is required for certification.

Certification of a successful completion of a bowhunter education course is a requirement to get a New Hampshire bowhunting license. ***Preregistration is requested, and enrollment is limited.***

Call Chief Instructor Fred Allen at 968-9944 for more information or to register for the course.

Pemi Fish and Game Club  
P.O. Box 38  
Plymouth, NH 03264-0038

*Change Service Requested*



PRESRT. STD.  
US POSTAGE  
**PAID**  
FRANKLIN, NH  
PERMIT NO. 65

**HIGHLIGHTS** (see page 3 for full schedule)

June 20 — NH State M1 Garand Championship  
June 27— Adopt-a-Highway  
June 27, 28 — Archery: IBO State Championship  
July 10-12 — Cowboy Action: the Fracas  
July 18 — Women on Target  
August 8, 9 — Machine Gun Shoot

---

Page 12 *Pemigewasset Valley Fish and Game Club Gazette—Vol. 15, No. 2*

June 2009

---

Visit us at our website at [www.pemi.org](http://www.pemi.org); e-mail us at [mail@pemi.org](mailto:mail@pemi.org)

## Officers and Directors

Randy Enger, President	(978) 443-5429
Joe Oustecky, VP	(603) 536-4129
Stuart Pitts, Treasurer	(603) 726-3037
Brian Pelchat, Secretary	(603) 968-3146
Fred Allen, Director	(603) 968-9944
John Bartlett, Director	(603) 786-9720
James Brennan, Director	(603) 539-5147
Tom Grabiek, Director	(603) 786-2152
Phil Haskell, Director	(603) 536-3105
Bob Klimm, Director	(603) 630-9408
Tim Korade, Director	(603) 536-1716
Don Marsh, Director	(603) 968-7039
Winnie Oustecky, Director	(603) 536-4129
Toni Piper, Director	(603) 968-2251
Marian Pitts, Director	(603) 726-3037
Jerry Thibodeau, Director	

Mike Baumann, Webmaster [applewize@spamcop.net](mailto:applewize@spamcop.net)  
Phil Haskell, Database Manager [three\\_birches@yahoo.com](mailto:three_birches@yahoo.com)

The Gazette is a newsletter publication of the Pemigewasset Valley Fish and Game Club, Holderness, New Hampshire. It is mailed quarterly to the membership: March, June, September, and December.

**EDITOR**

Randy Enger

**CONTRIBUTORS**

Fred Allen  
John Bartlett  
Randy Enger  
Phil Haskell  
Ev Tate

*Please address all comments regarding this publication to the editor by writing to:*

Gazette Editor  
Pemigewasset Valley Fish and Game Club  
P.O. Box 38 • Plymouth, NH 03264-0038

or send e-mail to [mail@pemi.org](mailto:mail@pemi.org)